

**COMPRESSOR**

Displacement (cm <sup>3</sup> )	7.39
Diameter (mm)	24.29
Stroke (mm)	15.94
Net Weight (Kg)	9.9
Oil type	ISO VG 19 ESTER
Oil charge (cm <sup>3</sup> )	345

**MOTOR**

Approximate Power (CV)	1/5
Voltage/Frequency (V/Hz)	220V 50Hz
Voltage range (V)	187-264
Code	62.006
Type	RSIR
Phase number	1 PH
Locked rotor current (A)	11.5
Main W. resist. at 25°C (Ω)	11.62
Start W. resist. at 25°C (Ω)	21.21

**APPLICATION**

Application	Low back pressure
Refrigerant	R134a
Evaporating (°C)	-35 to -10
Expansion	Capillar
Comp. cooling	Static
Max. ambient temp. (°C)	43

NOMINAL PERFORMANCE	CYCLE A	CYCLE B
Cooling capacity (kcal/h)	113	155
Input power (W)	144	153
EER (kcal/Wh)	0.78	1.01
COP (W/W)	0.91	1.17
Current (A)	1.01	1.05

**TEST CONDITIONS**

Evaporating temp. (°C)	-25.0	-23.3
Condensing temp. (°C)	55.0	55.0
Liq.t. entering expan. (°C)	55.0	32.0
Ambient t. and return (°C)	32.0	32.0
Tens/Freq (V/Hz)	220V 50Hz	220V 50Hz

**ELECTRICAL COMPONENTS**

Relay	PTC 3003 - K100			
Nominal voltage (V)	200 - 240			
Resistance μ	14,00			
Protector	MRP317LZ	T0502	AF15BW	4TM293NFBY Y
Current (A)	9.4	9.0	8.2	9.9
Time check (seg)	7.5 14	7.5-14	7.5-14	5-15
Disc temp. (Open/Close) (°C)	120.0 / 61.0	130.0 / 62.0	130.0 / 62.0	120.0 / 61.0

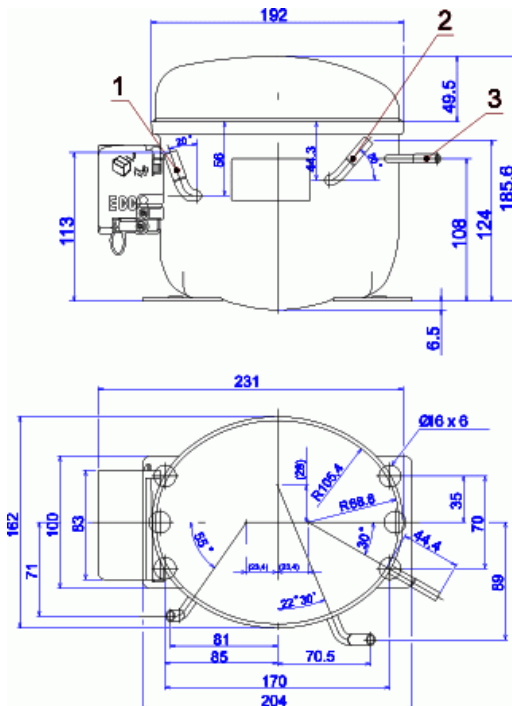
**DIMENSIONS AND ELECTRICAL DIAGRAM**

	DESIGNATION	INTERNAL DIAM. (MM)
1	Suction/Service	6.5
2	Service/Suction	6.5
3	Discharge	4.9

**RSIR**

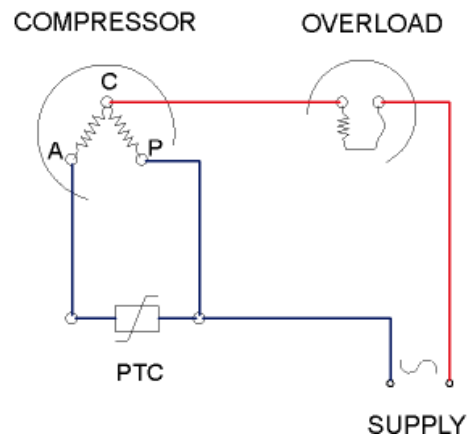

**TEST CONDITIONS**

Voltage/frequency	220V 50Hz
Ambient t. and return	32 °C
Liq.t. entering expan.	Subcooling at 32 °C

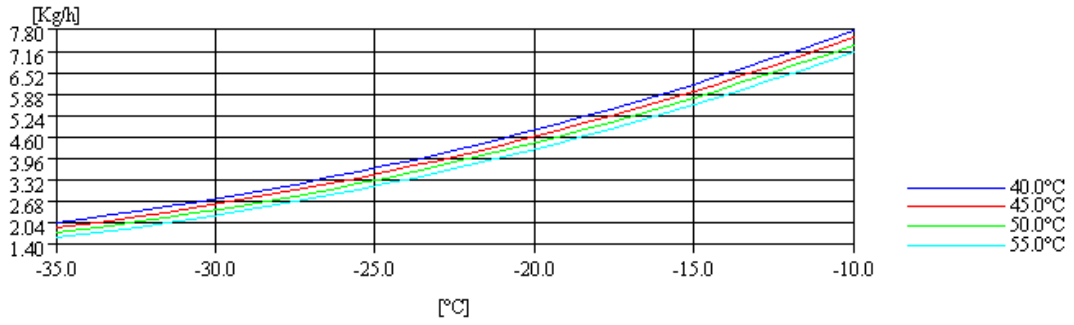
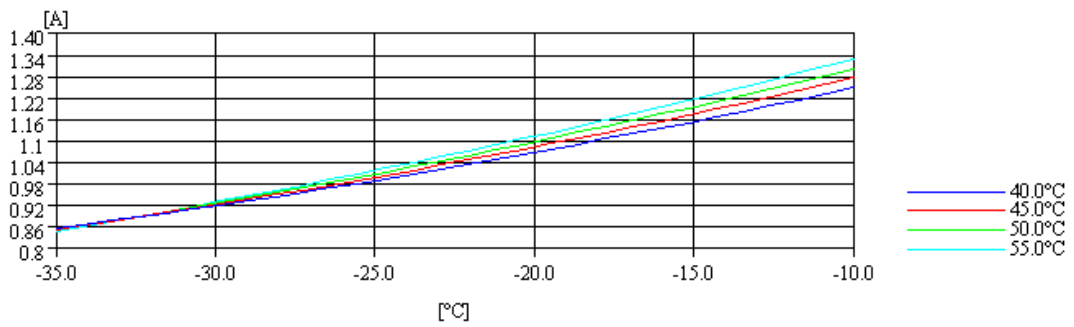
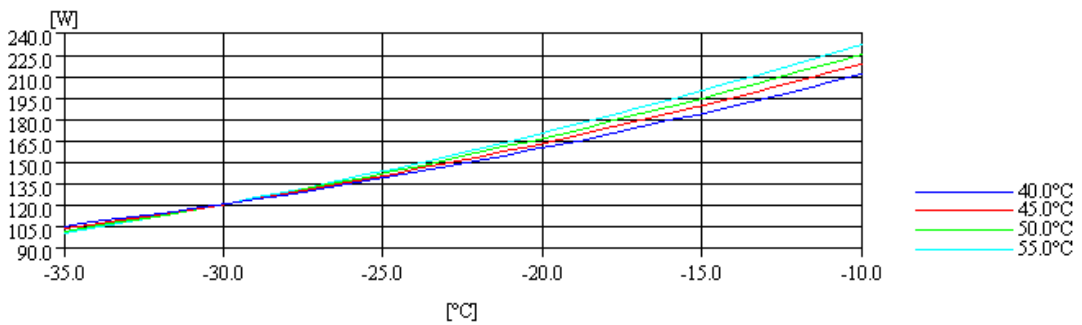
**MASS FLOW**

**INTENSITY**

**CONSUMPTION**

**COOLING CAPACITY**
